

# Innovative injection system in desulphurization plants

The patented 'PFD Dense Phase Conveyor' represents a new technology in dense phase conveying of solids.

At ThyssenKrupp Steel the technology conveys desulphurization agents with utmost precision. After more than eight years of continuous operation it has been proven that, in comparison to conventional technologies, a PFD dense phase conveyor increases process efficiencies, reduces the amount of desulphurization agents needed, speeds up the desulphurization process and, thus, increases the productivity of the steel plant.

Feldhaus-Technik GmbH seeks a cooperation partner to market the PFD dense phase conveyor on an international scale.

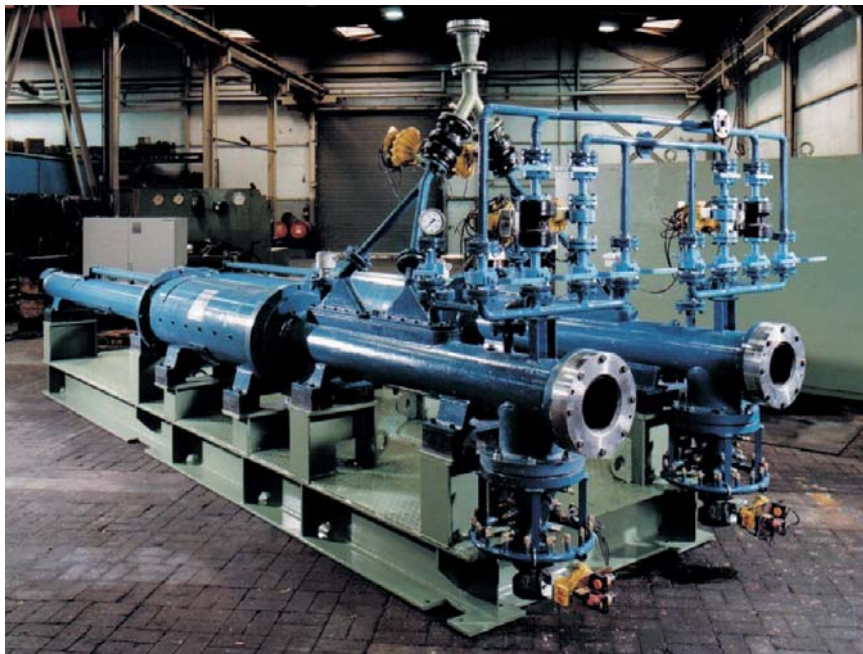

Figure 1. Pilot plant at ThyssenKrupp Steel

## Introduction

The patented PFD dense phase conveyor is able to convey all kinds of solids non-stop against high pressures (0.1 bar to > 20 bar) according to desired output rates; preferably via dense phase but also via dilute phase conveying. The size distribution can vary in any composition from 0 to 5 mm; the bulk density should range within 0.2 and 5 kg/dm<sup>3</sup>. The explosion-proof machine does not require an exhaust air filter and can be operated with any carrier gas, e.g. with nitrogen but also with critical carrier gases such as oxygen or natural gas.

In contrast to conventional technologies, the PFD dense phase conveyor responds immediately to set points and shows superior precision capabilities coupled with a high flexibility in the amounts injected. The conveyor's operation principle is based on volumetric dosing which implies a proactive regulation of the material flow (no control loops). Due to its coercive dosing principle, oscillating pressures and typical crane movement induced vibrations in the construction do not

affect the precision capabilities. Conveying rates range from small quantities (e.g. 0.1 to 1.0 kg/min), via middle quantities (e.g. 0.5 to 15 kg/min), up to large quantities (e.g. 10 to 100 kg/min).

## Operation principle

The conveyor had been developed in order to convey granulates in dense phase systems, triggered by the fact that conventional mass-flux controlled pressure vessels (gravimetric weight deviation) are unable to cope with the precision requirements in desulphurization plants. Since flowing quantities cannot be directly measured in pneumatic transport systems, the only means to achieve output control is to derive the actual output from the declining weight of the pressure vessel. This derived value, however, is obsolete when being computed and is therefore not suitable as a reference input for automatic control loops. In addition to that, unknown gas quantities diffuse from the top of the pressure vessel through the layer of granulates into the conveyor line which, as a

Thomas Feldhaus, Bernd Feldhaus, **Feldhaus-Technik GmbH**, Duisburg, Germany

Contact: [www.feldhaus-technik.de](http://www.feldhaus-technik.de)  
E-mail: [info@feldhaus-technik.de](mailto:info@feldhaus-technik.de)

result, causes a pulsing output of material. Finally, calculations are biased due to crane movement induced vibrations in the steel construction.

### Application at ThyssenKrupp Steel

ThyssenKrupp Steel operates two steel plants in Duisburg, Germany. The desulphurization plants in steel plant No. 1 were newly built in 1998 by Küttner GmbH & Co. KG in a modern but conventional way. The desulphurization plants in steel plant No. 2, however, were upgraded in 1999 and in 2004 with PFD dense phase conveyors.

ThyssenKrupp Steel has operated the PFD pilot plant since 1999 (figure 1). After further development the actuation system was modified resulting in a second conveyor. It has been used continuously since October 2004 conveying magnesium granulates at a rate of 3 kg/min up to 15 kg/min (size distribution 0.2 mm to 0.8 mm, bulk density 1 kg/dm<sup>3</sup>, see figure 2). Built by ThyssenKrupp Anlagen Service in cooperation with Feldhaus-Technik and commissioned by Feldhaus-Technik, both machines enlarge the desulphurization plants from co-injection to tri-injection and operate in combination with conventional pressure vessels for conveying calcium carbide (CaC<sub>2</sub>) and lime. The pre-assembled machines have been integrated in the desulphurization plants without disturbing production.

At ThyssenKrupp Steel the conveyors are situated farthest away from the ladle enabling the magnesium grain to remove the inside of the conveyor line from lime cakings. In March 2007 ThyssenKrupp Steel disclosed an expert's report that details the technical and economical advantages of the technology as following.

**Comparison with conventional systems.** The objective in pneumatic dense phase conveying systems is to maintain a dense and direct material flow. In conventional pressure vessels large volumes are filled with gas, which makes it difficult to achieve this objective. The PFD dense phase conveyor, however, requires only little amounts of gas and small conveyor line diameters and does maintain a dense material flow.

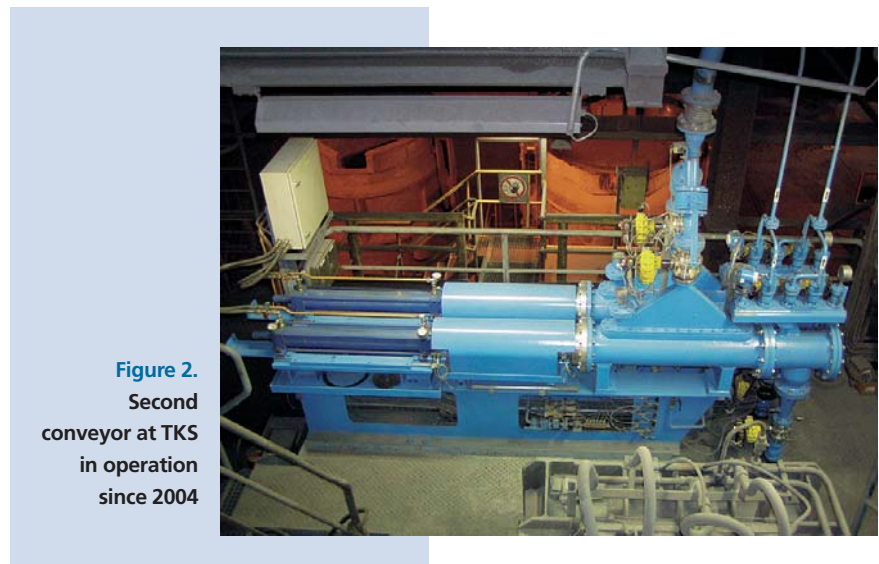

**Figure 2.** Second conveyor at TKS in operation since 2004

Conventional technologies might be suitable, if powdery materials are to be transported. However, when granulates are transported, particularly against high and fluctuating pressures and in co- or multi-injection systems, conventional methods cannot sustain a steady flow of material. The illustrations in figures 3 and 4 compare the magnesium output of the conventional technology with the output of the PFD dense phase conveyor at ThyssenKrupp Steel at transfer pressures of 5 bars.

Today's dense phase conveying methods utilize screw feeders, rotary feeders or flow control valves and are based on mass-flux control and control loops. Different pressure zones between the pressure vessel and the receiver vessel are inherent, i.e. heavy wear is inevitable due to the many and tight cleavages. A further major disadvantage of granulate conveyance

by common methods is that an unknown quantity of gas flows from the pressure vessel through the layer of granulates into the conveyor line to the receiver vessel. The consequence is a pulsing and inaccurate output. In contrast to that, the PFD dense phase conveyor features equal pressures at all times while only little amounts of transport gas are needed, which results in a smooth and even conveyance.

All moving parts inside the conveyor travel in slow motion, i.e. jacket, piston and output cone are free of wear. Induction and escape valves that are partly made of ceramics, which are still the initial sets, are actuated only when pressures on both ends are equal, which enhances durability to many years. At ThyssenKrupp Steel only the piston seal rings are replaced every ten months as a precautionary measure.

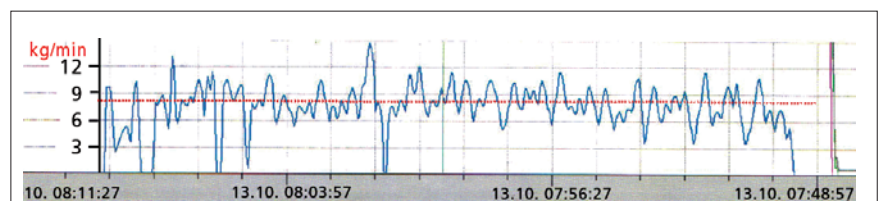

**Figure 3.** Oscillating Mg output using a conventional pressure vessel (set point 8 kg/min, pressure 5 bar)

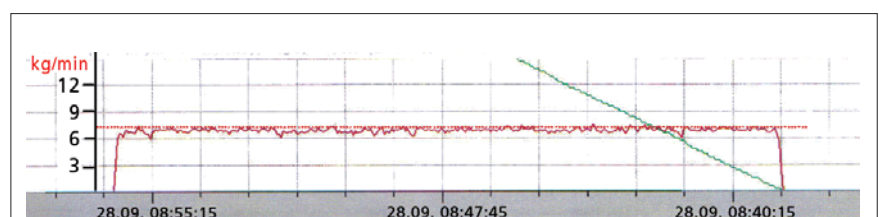

**Figure 4.** Mg output using a PFD conveyor (set point 7 kg/min, pressure 5 bar)



**PFD description.** The underlying principle can be compared with a two-piston pump (figure 5) based on volumetric output that always precisely meets the desired output - accurate and repeatable. In non-stop operations the conveyor consists of two units, in case of intermittent operations one unit is sufficient. Assuming a piston displacement of  $1 \text{ dm}^3/\text{min}$  and a bulk density of  $3 \text{ kg}/\text{dm}^3$ , the output will be exactly 3 kg of material per minute. In case of volatile bulk densities a correction factor will be considered.

Figure 6 shows a schematic of the installation site at ThyssenKrupp Steel. The feeding system consists of a portable container with an attached bunker below. Empty containers can be replaced without interrupting the

process. Alternatively, the conveyor can withdraw material from a silo, which can be replenished at all times. Figure 7 shows the conveyor's control pattern. Each unit is equipped with a programmable linear drive that can be a hydraulic cylinder or an electro-mechanic actuator. A hydraulic control system determines the pace at which the piston moves forward ( $0.2 \text{ m}/\text{min}$  on average) aiming at a stroke duration of 4 to 5 minutes. When the operating piston reaches its end position, the second piston takes over. While piston No. 2 is in operation, piston No. 1 moves backwards at approx.  $1.5 \text{ m}/\text{min}$ . Supported by the induced draught of the piston, material flows through the induction valve into the interior of the cylinder.

The hydraulic cylinder carries and drives the piston that runs on a plain bearing through a sealing into the interior of the main cylinder. The piston is dimensioned in accordance with the desired output rate of the conveyor. At ThyssenKrupp Steel the piston diameters are 200 mm in size which, in combination with an 800 mm stroke, allows an output rate between 3 kg and 15 kg per minute.

The particular inlet geometry ensures that both cylinders are completely filled with material. When the piston moves forward, the material falls down the outlet cone and is, accelerated by the carrier gas to dense phase speed, pushed into the conveyor line. If a congestion is about to emerge (pressure ramp-up), the piston stops without interrupting the process and restarts when pressures are normalized again. The operator can carry out a system check from the control room, i.e. the machine does not require any on-site maintenance.

**Specifications.** Figure 8 shows a possible performance range of a conveyor that is dimensioned for conveying rates of  $0 \text{ kg}/\text{min}$  to  $10 \text{ kg}/\text{min}$  of material. A standard control system made by BoschRexroth precisely levels the velocity at which the piston moves forward. Consequently, the actual output always meets the desired value. The diagram shows further that the conveyor maintains a constant pneumatic transportation for days or weeks. A PFD dense phase conveyor can be laid out as a portable device but can also be stationary, located beneath silos or Big-Bags. The machine can be situated below or above the receiver and does not require any specific installation site. Decoupling from vibrations is not necessarily. Thanks to the very dense and direct transport of material, conveyor lines can be, in contrast to conventional dense-phase conveyor lines, considerably long and small in nominal width.

## Further areas for improvement

**Injecting calcium carbide granulates.** Considering the inherent constraints with pneumatic dense phase conveyor systems that are equipped with pressure vessels, composites of calcium carbide were used as desulfurization agents

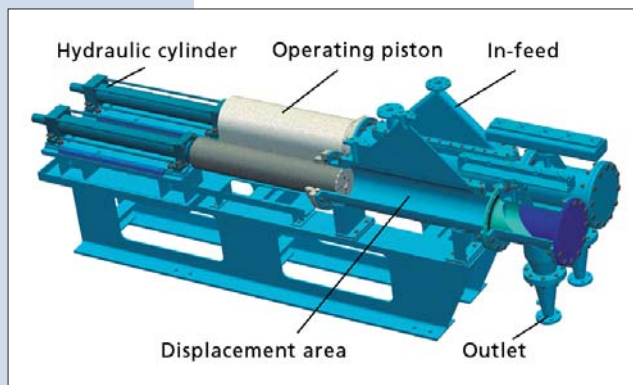

Figure 5. Key components of the PFD dense phase conveyor

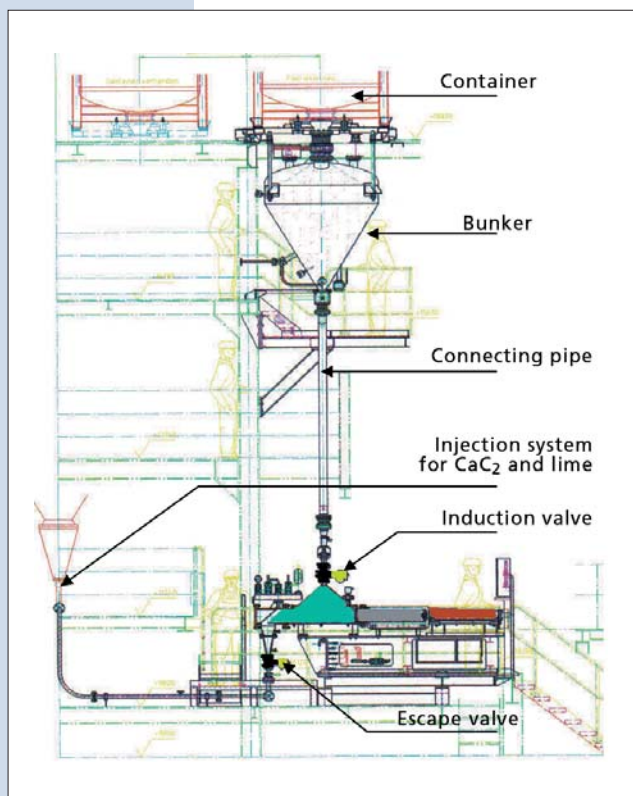

Figure 6. Schematic installation at ThyssenKrupp Steel

featuring size distributions between 0.01 and 0.1 mm maximum. The fine size distribution ensures that gas does not diffuse from the top of the vessel through the conveyor line. By fluidizing, the powdery calcium carbide flows with ease through the conveyor line and the lance into the cast. Coarse-grained material has never been applied because too much gas would diffuse through the layer of material into the conveyor line. Subsequently, the amounts of gas would serve as a placeholder inside the conveyor line blocking the material flow, which in turn would result in a detrimental flowing behaviour and in missing the required output. Following the oscillating and uneven flow of material, congested lance holes would be the consequence due to a momentary undersupply of material. By the same token, higher amounts of gas would be supplied in when the oscillating flowing pattern peaks. This momentary oversupply of gas at the lance holes would cause heavy turbulences inside the ladle.

In consideration of these limitations, powder-like calcium carbide or composites of calcium carbide (size distribution 0.01 - 0.1 mm) are injected worldwide to ensure an even flow of material. This notion is supported by the fact that magnesium - that has to be injected in granulates because of safety reasons (size distribution 0.2 - 0.8 mm) - flows in an even more oscillating way out of conventional pressure vessels at even lower conveying rates.

However, while paying tribute to these constraints, the trade-off is a metallurgical effect that revolves worldwide approx. around 0.3 (30%), which cannot be acceptable in modern desulphurization processes. Due to the agglomeration of the fine and powder-like particles, clusters of calcium carbide or of composites of such appear in the cast. These clusters are either free-floating inside the cast or are enclosed in carrier gas bubbles. Either way, accelerated by the light density of gas and calcium carbide and supported by the kinetic energy, these clusters quickly merge straight through the slag to the surface of the cast. Calcium carbide that reaches the slag once cannot repeat its journey, and therefore remains unavailable for the desulphurization process. When departing the lance hole, lose clusters

**Figure 7.**  
Control pattern  
of the PFD  
conveyor

**Figure 8.**  
Possible  
performance  
range of a PFD  
conveyor

of fine particles are compressed to dense agglomerations that are several millimetres in size due to the enormous static pressure. As a consequence, only the border areas of these clusters get in touch with the cast while the majority of the desulphurization agent floats to the surface without making any contact with the cast. There is a consensus of opinion that the overall metallurgical effect of calcium carbide ranges between 30 and 40%. This very low number is evident since 60 - 70% of the material injected can be traced in the slag after the desulphurization process [1].

Based on these pre-conditions, a PFD dense phase conveyor could reap the full potential of calcium carbide and composites of calcium carbide in desulphurization processes. As a matter of fact, the conveyor is capable of injecting high amounts of solids into the hot metal against high pressures with utmost precision; reliable and safe. By employing the technology in order to inject calcium carbide granulate (size distribution e.g. 0.1 - 1 mm), the entire particle makes contact with the cast and will stay underneath the surface

until being consumed entirely. Our basic proposition is that the individual particles do not tend to form clusters since they do not bond with each other. Hence, every single particle is fully exposed to the cast and is not enclosed by any sort of carrier gas. Further, the static pressure of the bath will diffuse through the individual particles without compressing them to clusters.

In brief, every single particle merges with the cast and contributes to the pursued metallurgical effect. If a particle is not entirely consumed on the way up, it will be immediately pulled back into the cast because of the current in the bath. The end result will be a significant increase in efficiency and a significant shortening of treatment times.

RWTH Aachen University has investigated that the injection of coarse-grained material leads to a higher efficiency in desulphurization processes. Desulphurization agents have been injected by means of a coherent jet into the hot metal. When coarse-grained material with low particle density was injected, the efficiency was significantly higher as opposed to trials when fine-grained

material was injected [2]. The University of Aachen would like to conduct trials in their pilot plant stations to prove the exact correlation between the injection of calcium carbide granulates and a significant increase in efficiency in desulphurization processes. Feldhaus-Technik GmbH seeks a partner institution that contributes to the financial expenditures associated with the trial runs to participate in the results and in the IPP rights that are already filed.

### Improvement of desulphurization.

As a matter of fact, PFD dense phase conveyors have significantly raised the efficiency of desulphurization plants at ThyssenKrupp Steel albeit operating in conjunction with two conventional pressure vessels, which means physical constraints still play a major role in the desulphurization process. The conveyor must account for the limitations of the pressure vessels because it is the dominating facility due to its coercive dosing principle.

Based on the positive experience made over the past 8 years at ThyssenKrupp Steel, the next step must be a desulphurization plant for co- or multi-injection that is equipped with PFD dense phase conveyors only, because of the following advantages:

- simple fully-automated process (no control loops),
- no supervizing personnel needed,
- individual desulphurization agents can be injected in any grain size to maximize efficiencies,
- shortening of process times.

**Other fields of application.** A PFD dense phase conveyor could inject Fe-particles through tuyères into cupola furnaces in foundries. The material could be preheated and injected with

pure oxygen to prevent the coke bed from cooling down.

In the steel industry coarse dusts with 70% Fe-particles could be easily fed back into the process by injecting the material into the LD-converter through the converter's tap hole or the converter's mouth. Steel mill dusts and pulverized coal could be co-injected into furnaces or OxiCup shaft furnaces using natural gas or oxygen as a carrier gas to replace today's costly stone forming processes from Fe-dusts, pulverized coal and binders.

Pyrophoric dusts could be transported using compressed air, natural gas, nitrogen or oxygen as carrier gas. Dusts could be preheated to avoid a decrease in process heat.

With regard to the closed loop recycling management, dusts could be easily processed and Fe-fractions recaptured (in foundries 100 kg/t of cast iron; in steel plants 1.5 t of coarse dusts per 270 t of steel).

Based on the success in the steel industry, the PFD dense phase conveyor will be applied to pneumatic processes in the chemical industry. The task, however, is different to the extent that also very small quantities of powders are to be transported. Subsequently, a PFD dense phase conveyor has been developed that is able to convey all different sorts of solids (granulates and powders) also at very low conveying rates with utmost precision (e.g. in a particular case 0.1 - 3.75 kg/h of KCl into a reactor). This machine type encompasses all benefits from the previous versions.

In brief, a PFD dense phase conveyor is superior to conventional technologies when valuable bulk solids with a bulk density of  $> 0.5$  are to be pneumatically transported with utmost precision at high transfer pressures.

## Conclusion

The PFD dense phase conveyor initially has been developed to improve the injection of magnesium granulate through a submerged lance into the hot metal. However, the potential fields of application range well beyond the desulphurization process in steel plants. In October 2004 the second machine was put into operation at ThyssenKrupp Steel. Today two machines inject magnesium granulate into the hot metal desulphurizing more than 5 million t/year of hot metal. In February 2007 the patent application regarding a newly developed dense phase conveyor system comprising the performance feedback of the last few years was filed. With this newly developed machine all sorts of solids (also sludge and powder) can be transported pneumatically with absolute precision also at extremely low conveying rates. In March 2007 ThyssenKrupp Steel disclosed an expert's report that details the technical and economical advantages of the technology employed. In order to market the PFD dense phase conveyor on an international scale Feldhaus-Technik GmbH seeks a partner institution with relevant experience. An internationally well established company for measuring and process technologies is already cooperating with Feldhaus-Technik GmbH. ■

## References

- [1] Freißmuth, A.: Entschwefelung von Roheisen mit Calciumcarbid - der heutige Stand und mögliche Entwicklungen, Stahl und Eisen 117 (1997), No. 9, pp. 53-59
- [2] Senk, D., Gudenau, H.W., Wieting, T., Böttcher, G. and Stephany, C.: Der Lehrstuhl für Metallurgie von Eisen und Stahl an der RWTH Aachen anhand des Forschungsbeispiels "Metallurgischer Einsatz von Stäuben" BHM, Vol. 150 (2005), No. 11, pp. 377-378